

## Features

### CAN-Bus connectivity

- Electronic management of all components permitting quick and easy diagnosis
- All performance parameters can be configured exactly by the service technician for every individual mission

### Drive system

- Top speed 7.5km/h loaded and unloaded
- Automatic braking on releasing the travel switch
- Electromechanical braking initiated by the emergency stop button acts on the drive motor, proportion to the load carried
- Well controllable regenerative braking on reversing direction of travel

## Standard and Optional Equipment

### Standard Equipment

- Battery discharge indicator
- Suspension platform with skidproof mat
- Workstation incorporating storage compartments
- Fork 560/1150
- Power-assisted steering, adjustable steering resistance
- Automatic speed reduction on cornering
- AC drive motor
- Automatic braking on releasing butterfly switch
- Two fixed castor wheels
- Cushion drive wheel
- Tandem polyurethane load wheels
- Electric horn
- Low temperature protection to -10°C
- Electromagnetic emergency brake

### Optional Equipment

- Side battery change
- Fork 680/1150
- Polyurethane drive wheel
- Cold store version to -35°C
- Multifunctional display

## Other options available on request



## Electric Pallet Truck

CAPACITY 2000kg  
T20AP04 1158

### Safety

Three-way braking systems: automatic braking by LBC on releasing travel control switch; electromechanical braking when tiller is moved fully up or down; electronic braking by reversing travel control switch. Emergency stop button interrupts all electric circuits and actuates electromechanical brake. Round truck contours, no sharp edges, and all wheels contained within chassis, do not turn beyond truck contours. Hands protected within tiller head guard.

### Performance

The 1.5kW AC motor guarantees reaction on start-up and a high top speed, almost identical whether unloaded or loaded. The developed power is operated by LAC and is perfectly controlled.

### Comfort

Precision working at the highest level of performance calls for a high level of operator comfort. The platform is fitted with a flexible anti-vibration mat which dampens impacts. When

combined with electric steering, this new platform provides incomparable operating and handling comfort.

### Reliability

Tandem load wheels provide excellent reliable especially on the uneven ground. Each fork tip endures a load of 2,000kg without bending. Smooth entry of the fork into closed pallets is assisted by the ramped tip shape, lead-in and narrow width (165mm). Features that contribute to considerably longer truck lifetime as well as fast, easy and safe load handling.

### Service

Speed and economy continue over into truck diagnosis and preventive maintenance. CAN-Bus connectivity enables all truck data to be read out on laptop computer by the service technician. Swift access to all components and maintenance-free AC motors play an additional part in keeping truck uptime up.

## Features

### Linde control handlebars

- Ergonomic design and position
- Optimum protection for both hands
- All main control functions integrated in one handle for operation by either hand or both

### Power steering

- Proportional power assisted steering, effortless to operate
- Automatic speed reduction when cornering
- Adjustable steering feedback resulting in outstanding stability



### Battery and charger

- Vertical battery change
- Wide range of batteries (low & high) from 180Ah (2PzS) to 620Ah (4PzS)
- Wide range of standard and HF charger



### Workstation

- Battery discharge indicator
- Wide and deep storage compartments for wrapping paper, work gloves, writing utensils, etc.
- Soft mat platform for high operator comfort. Platform suspension with safety switch absorbs vibration and shock



### AC motor

- Powerful, smooth-running 1.5kW (at 100% performance) AC motor
- Moisture and dust-proof motor, maintenance-free
- Gradeability 13% fully loaded
- No rollback on uphill starting

\*Subject to modification in the interests of progress, illustration and technical details not binding for actual constructions and may show the optional equipments.\*

1158\_T20AP04\_D-01\_en\_201801

Linde Material Handling

Linde

## Technical Data

Characteristics	1.1	Manufacturer		Linde	
	1.2	Model designation		<b>T 20 AP</b>	
	1.3	Power unit		Battery	
	1.4	Operation		Stand-on	
	1.5	Load capacity	Q(kg)	2000	
	1.6	Load center	c(mm)	600	
	1.8	Axle centre to fork face (fork raised/lowered)	x(mm)	895/962	
	1.9	Wheelbase (fork raised/lowered)	y(mm)	1431/1497	
	Weights	2.1	Service weight (with battery item 6.5)	kg	867
2.2		Axle load with load, drive/load side	kg	1133/1734	
2.3		Axle load without load drive/load side	kg	706/161	
Wheels	3.1	Tyre, operator/load side: Rubber (R), polyurethane (PU)		R+P/P	
	3.2	Tyre size, drive side	mm	Ø 254 x 102	
	3.3	Tyre size, load side	mm	Ø 85 x 105	
	3.4	Auxiliary wheel, size	mm	Ø 125 x 40	
	3.5	Wheels number, drive/load side (x=driven)		1X+2/4	
	3.6	Track width, drive side	mm	544	
	3.7	Track width, load side	mm	355/395/515	
Dimensions	4.4	Lift	h <sub>3</sub> (mm)	125	
	4.8	Height of driving platform (low position)	h <sub>7</sub> (mm)	160	
	4.9	Height of tiller arm in operation position	h <sub>14</sub> (mm)	1103/1287	
	4.15	Fork height, lowered	h <sub>13</sub> (mm)	85	
	4.19	Overall length	l <sub>1</sub> (mm)	2288	
	4.20	Length to fork face	l <sub>2</sub> (mm)	769 <sup>1)</sup> /1138 <sup>2)</sup>	
	4.21	Overall width	b <sub>1</sub> (mm)	790	
	4.22	Fork dimensions	s/e/l(mm)	165x55x1150	
	4.25	Fork spread	b <sub>5</sub> (mm)	560/680	
	4.32	Ground clearance, center of wheelbase min./max.	m <sub>2</sub> (mm)	30/155	
	4.33	Aisle width, 1000x1200mm pallet crosswise	Ast(mm)	1999 <sup>1)</sup> /2336 <sup>2)</sup>	
	4.34	Aisle width, 800x1200mm pallet lengthwise	Ast(mm)	2199 <sup>1)</sup> /2536 <sup>2)</sup>	
	4.35	Turning radius (fork raised)	Wa(mm)	1694 <sup>1)</sup> /2031 <sup>2)</sup>	
	Performances	5.1	Travel speed, with/without load	km/h	7.5
		5.2	Lifting speed, with/without load	m/s	0.036/0.043
5.3		Lowering speed, with/without load	m/s	0.064/0.060	
5.8		Max. Climbing ability, with/without load	%	13/20	
5.10		Service brake		Electro-mechanical	
Drive	6.1	Drive motor output (60 min.rating)	kW	1.5	
	6.2	Lift motor output (15% rating)	kW	1.2	
	6.3	Battery according to DIN 43 531/35/36A,B,C,no		DIN 43535 B	
	6.4	Battery voltage/rated capacity (5h)	V/Ah	24/345	
	6.5	Battery weight	kg	297	
Others	8.1	Type of drive control		LAC variator	
	8.4	Noise level at operator's ear	dB(A)	<70	
Figures for standard version may vary when optional equipment is fitted 1) Folded platform 2) Unfolded platform					

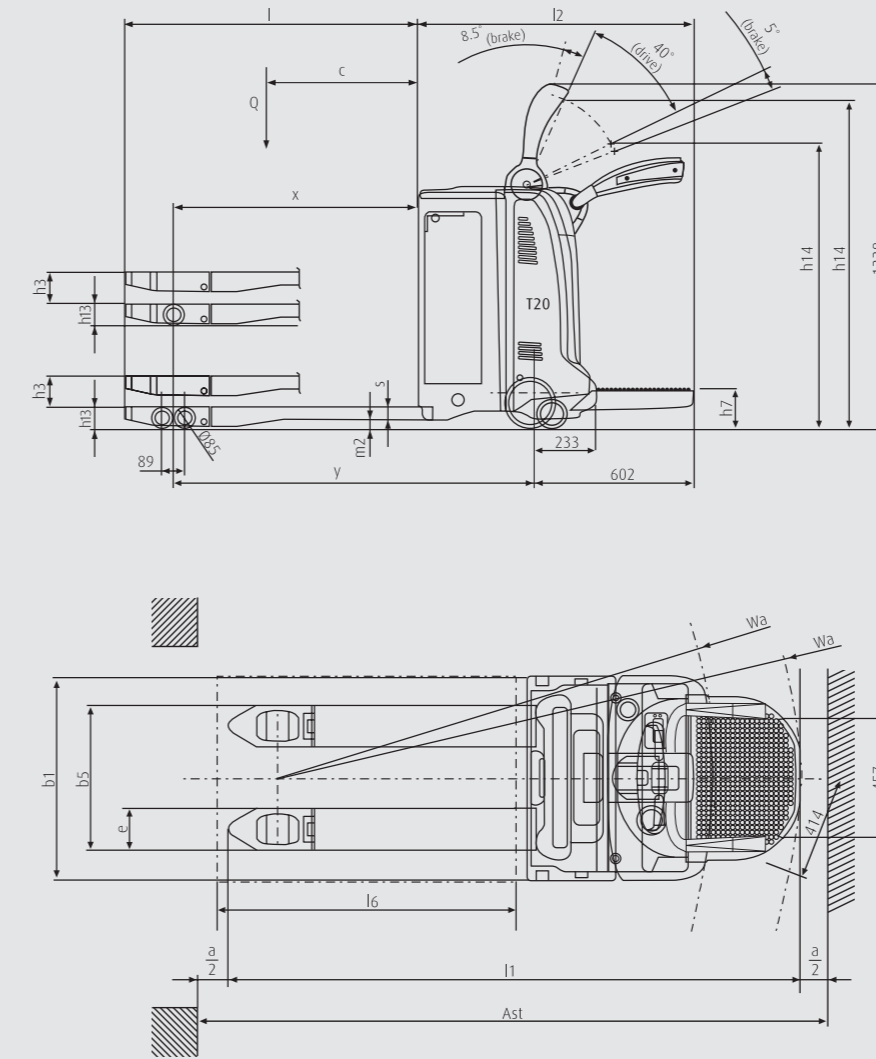

$Ast = Wa - x + l6 + a$   
 Security distance  $a = 200\text{mm}$

